

# How can one Generate Maximum Profit from a Moulding Shop



**Ferromatik Milacron India Pvt. Ltd.**  
**Hyderabad**

**M. Amarnath**  
**Sr. Manager - Sales**

# The Efficiency Conundrum

$$\text{Efficiency } (\eta) = \frac{\text{Output}}{\text{Input}}$$

## Output – To Maximize

- ✓ Higher Production
- ✓ Higher Utilization of Equipments

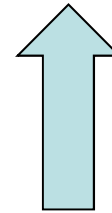

## Input Endowment – To Minimize

- ✓ Raw Material
- ✓ Energy Consumption
- ✓ Manpower
- ✓ Space

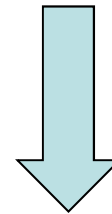

# Benefits of Efficiency

- ✓ Cost Competitive
- ✓ Consistent Quality Performer
- ✓ Maximum utilization of Resources
- ✓ Increase Up Time of Equipments
- ✓ Consistent **Supplier of Choice...WIN MORE BUSINESS**



*Efficiency - Quality components and Cost effective production in stipulated Time while maximizing the use of Resources applied*

# Elements of Efficiency

- ✓ Factory & Shop Floor Layout
- ✓ Waste Elimination at Various Stages
- ✓ Automation for Consistency
- ✓ Selection of Appropriate Process Technology
- ✓ Selection of Appropriate Equipments

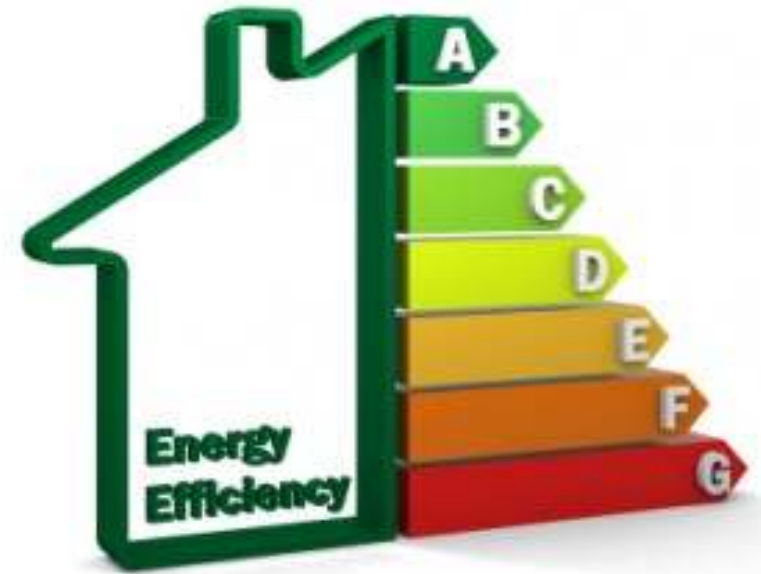

# Elements of Efficiency

- ✓ **Factory & Shop Floor Layout**
- ✓ Waste Elimination at Various Stages
- ✓ Automation for Consistency
- ✓ Selection of Appropriate Process Technology
- ✓ Selection of Appropriate Equipments

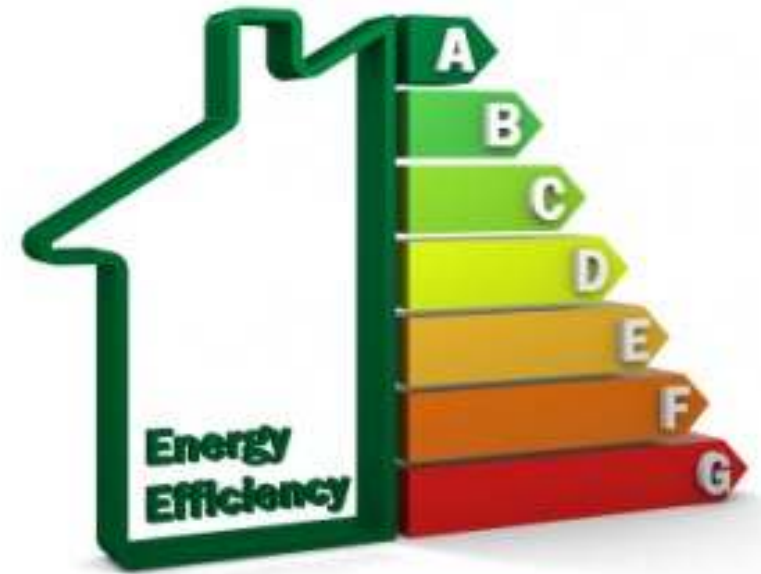

# Layout Characteristics

✓ Effective use of available Space – Becoming Scarce Resource

✓ No Hindrance & Smooth Flow of Material:

Raw Material → Production Parts → Assembly →  
Packing → Finish Goods Shipment

✓ Better Supervision - A good plant layout enables the supervisor to have a hawk's eye on the entire shop floor

✓ Layout should address High Safety & Working Conditions – High Employee Morale

✓ Improved utilization of Manpower - Process flow should be planned in such a way that least Movements of Manpower is carried out



# Elements of Efficiency

- ✓ Factory & Shop Floor Layout
- ✓ **Waste Elimination at Various Stages**
- ✓ Automation for Consistency
- ✓ Selection of Appropriate Process Technology
- ✓ Selection of Appropriate Equipments

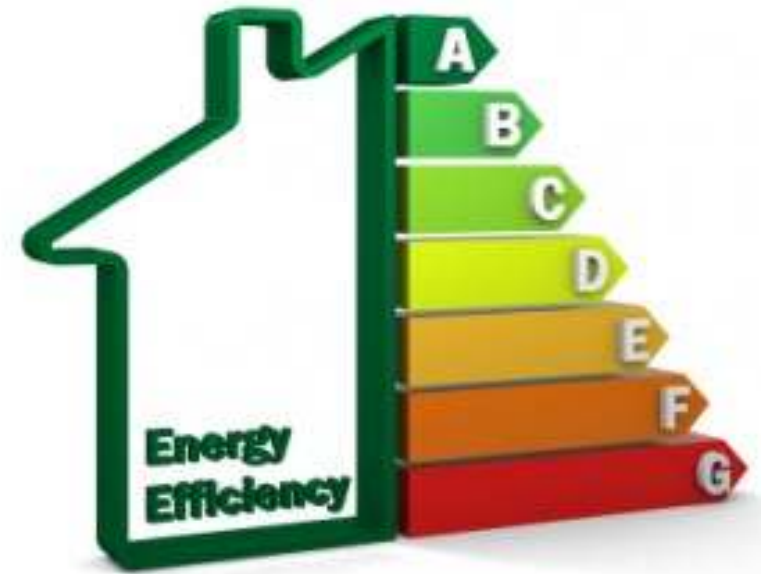

# Waste Elimination

## What is “Waste” ?

Whatever does not add value or Deliver Benefit

## “Waste” We can see in

- ✓ Floor Space
- ✓ Walking Distance
- ✓ Inventory
- ✓ Rejection
- ✓ Cycle time
- ✓ Manpower





# Waste Elimination

- ✓ Minimize the Time for Mould Change – Planned Preparation for Mould Change
- ✓ Runner less / Hot Runner Moulding
- ✓ Reduce Mould set up Time – Use historical Data for Quick Set up
- ✓ Automation – Material Loading System, Conveyor & Robots for increase consistency, Reduced Rejection & Effective utilization of Man Power
- ✓ Moulding Process Optimization
- ✓ Preventive Maintenance of IMM & Equipment



# Elements of Efficiency

- ✓ Factory & Shop Floor Layout
- ✓ Waste Elimination at Various Stages
- ✓ **Automation for Consistency**
- ✓ Selection of Appropriate Process Technology
- ✓ Selection of Appropriate Equipments

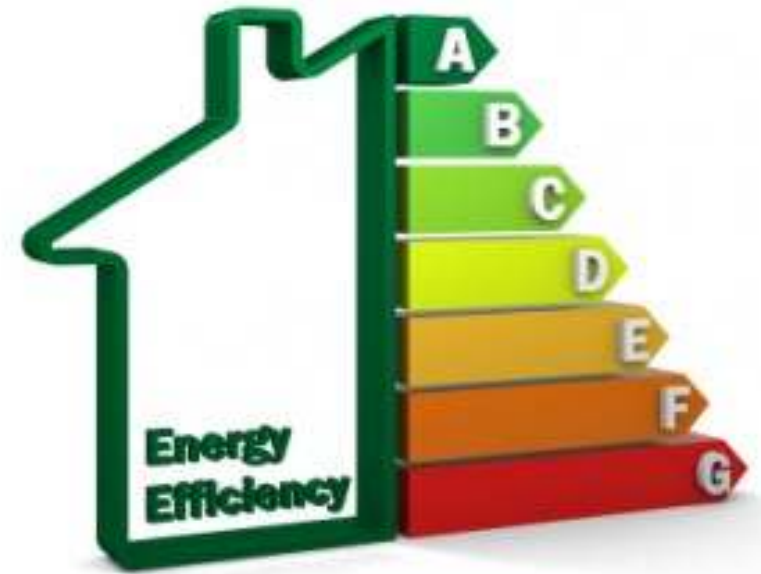

# Automation

## Areas of Possible Automation

- ✓ Mould Changing System
- ✓ Material Feeding System
- ✓ Product Removal & Transfer System
- ✓ Information Management System



# Automation

## Scope for Automation in Moulding Shop

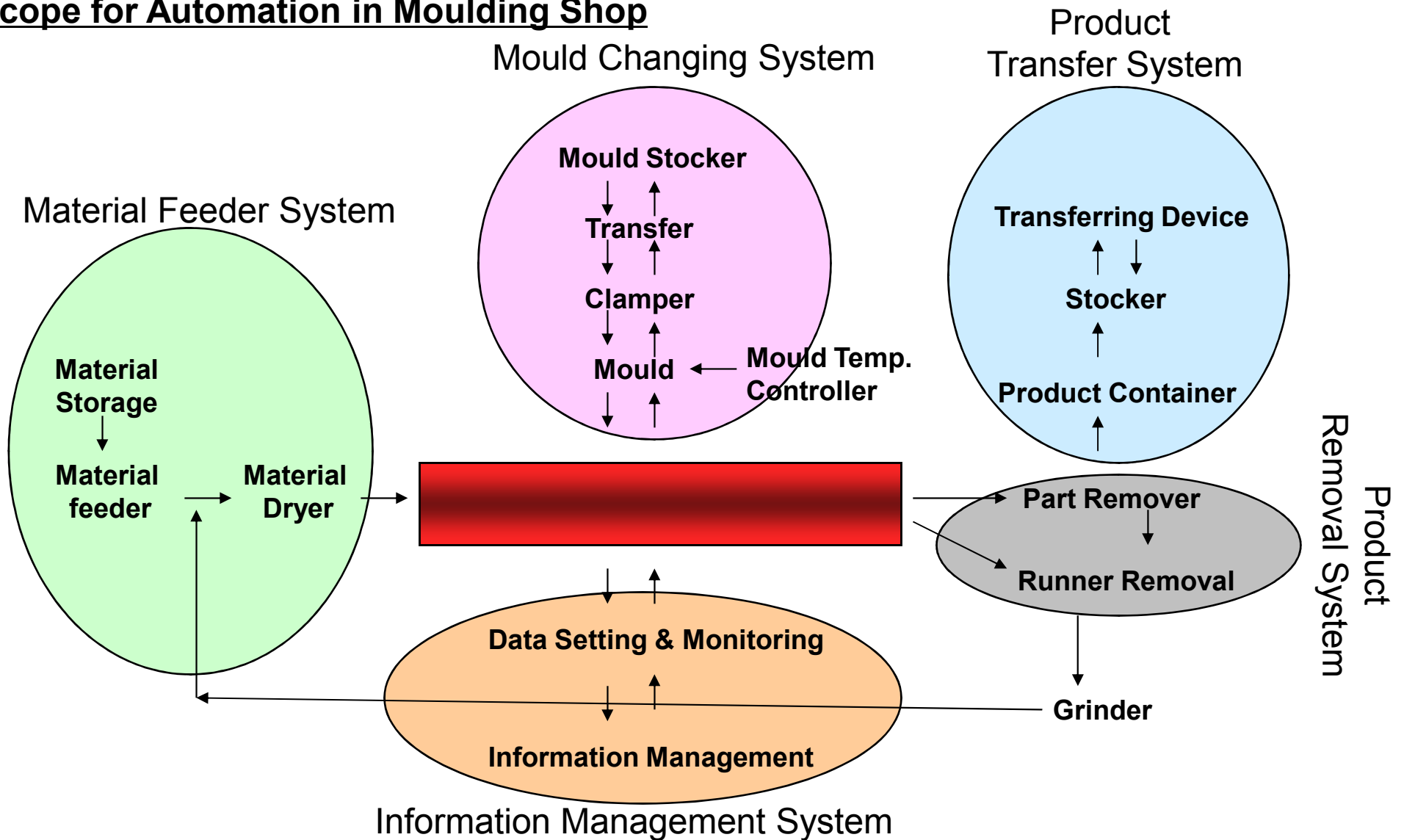

# Automation

## Areas of Possible Automation

- ✓ ***Mould Changing System***
- ✓ Material Feeding System
- ✓ Product Removal & Transfer System
- ✓ Information Management System



# Automation

## Mould Changing System

- Mould Loading / Unloading
- Mould Clamping / Unclamping
- Mould Connections

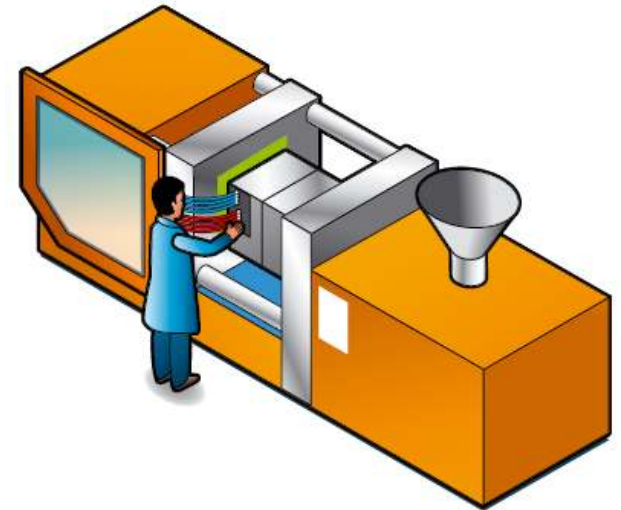
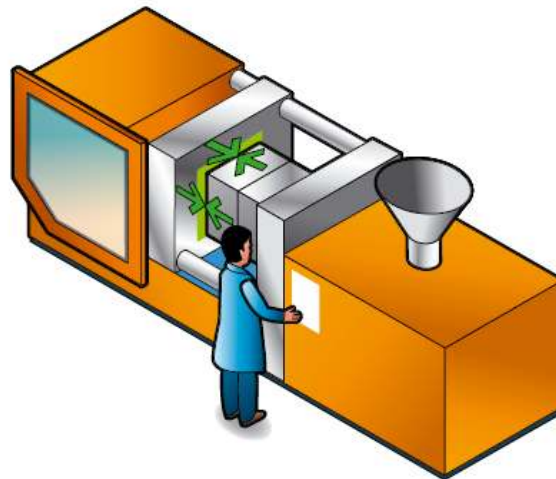
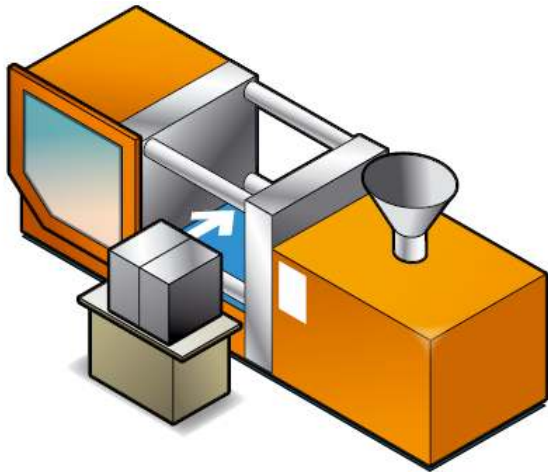

# Automation

## Mould Changing System

- **Mould Loading**
  - ✓ Stationary tables
  - ✓ Rail Carts
  - ✓ Movable Carts

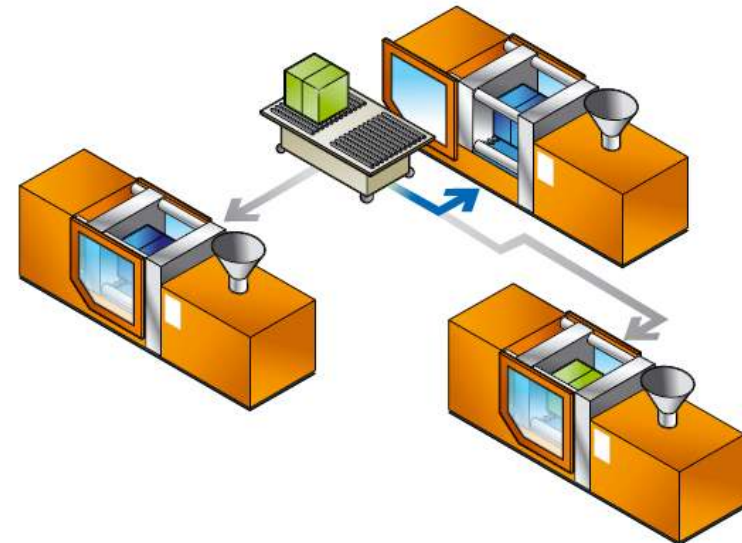
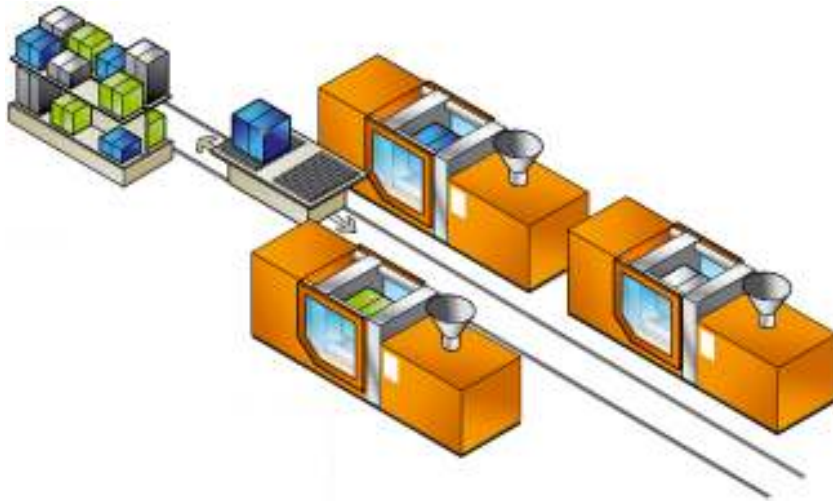
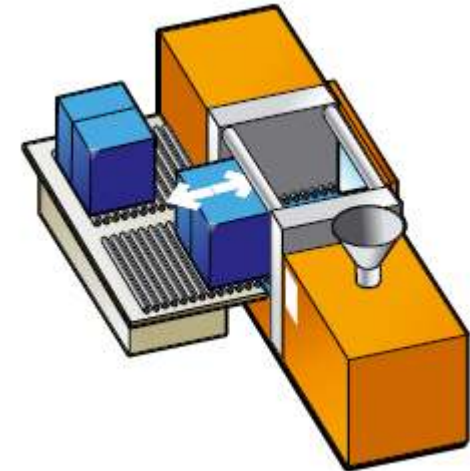

# Automation

## Mould Changing System

- Mould Loading
- Mould Clamping
  - Mechanical QMC
  - Hydraulic QMC
  - Magnetic QMC

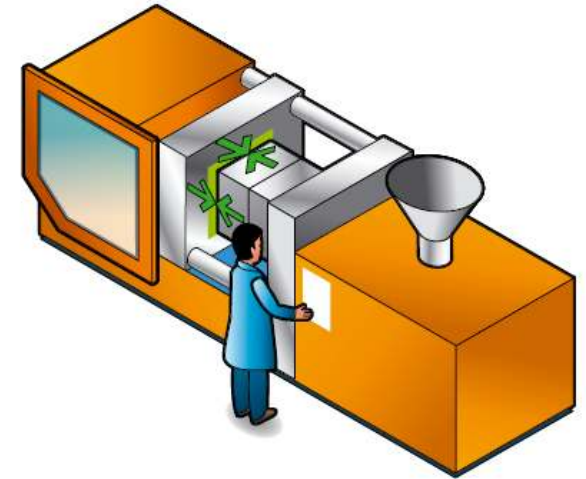

Mould **clamping**





# QMC Video



# Automation

## Mould Changing System

- Mould Loading
- Mould Clamping
- **Mould Connections**
  - QRC for Water Connections
  - QRC for Hydraulic Connections
  - QRC for Multiple Connections

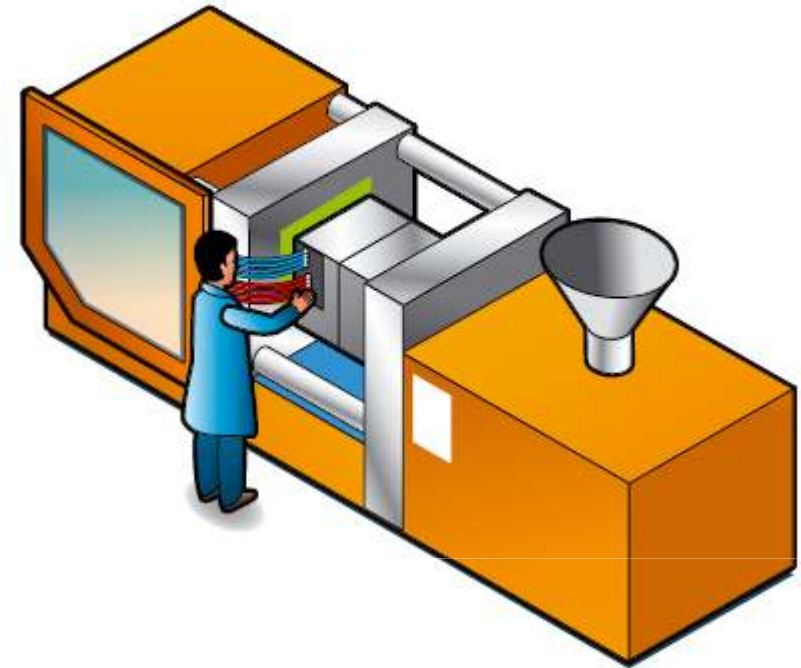

# Automation

## Areas of Possible Automation

- ✓ Mould Changing System
- ✓ **Material Feeding System**
- ✓ Product Removal & Transfer System
- ✓ Information Management System



# Automation

## Material Feeding System

- Auto Loaders
- Dozing Systems
- Ratio Loaders
- Central Conveying System



# Automation

## Areas of Possible Automation

- ✓ Mould Changing System
- ✓ Material Feeding System
- ✓ **Product Removal & Transfer System**
- ✓ Information Management System



# Automation

## Product Removing System

- Sprue Pickers
- Article Pick & Place Robots
- Finished Product Conveyor Belts

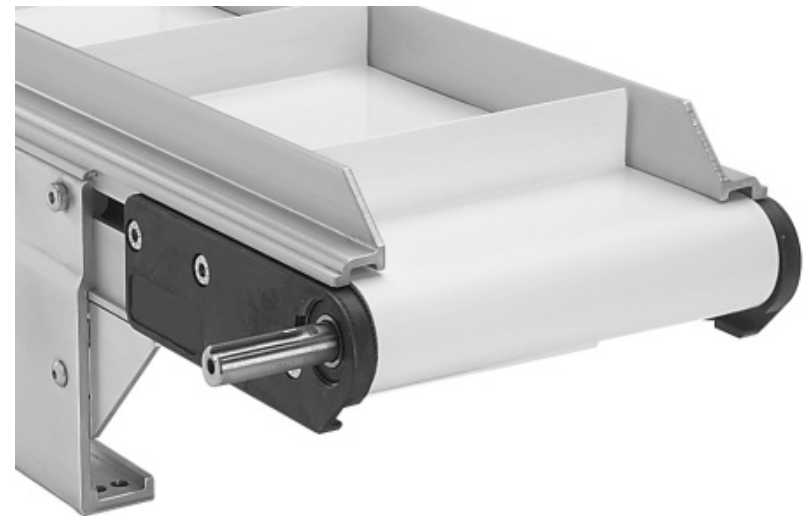

# Article Pick and place Robot Video

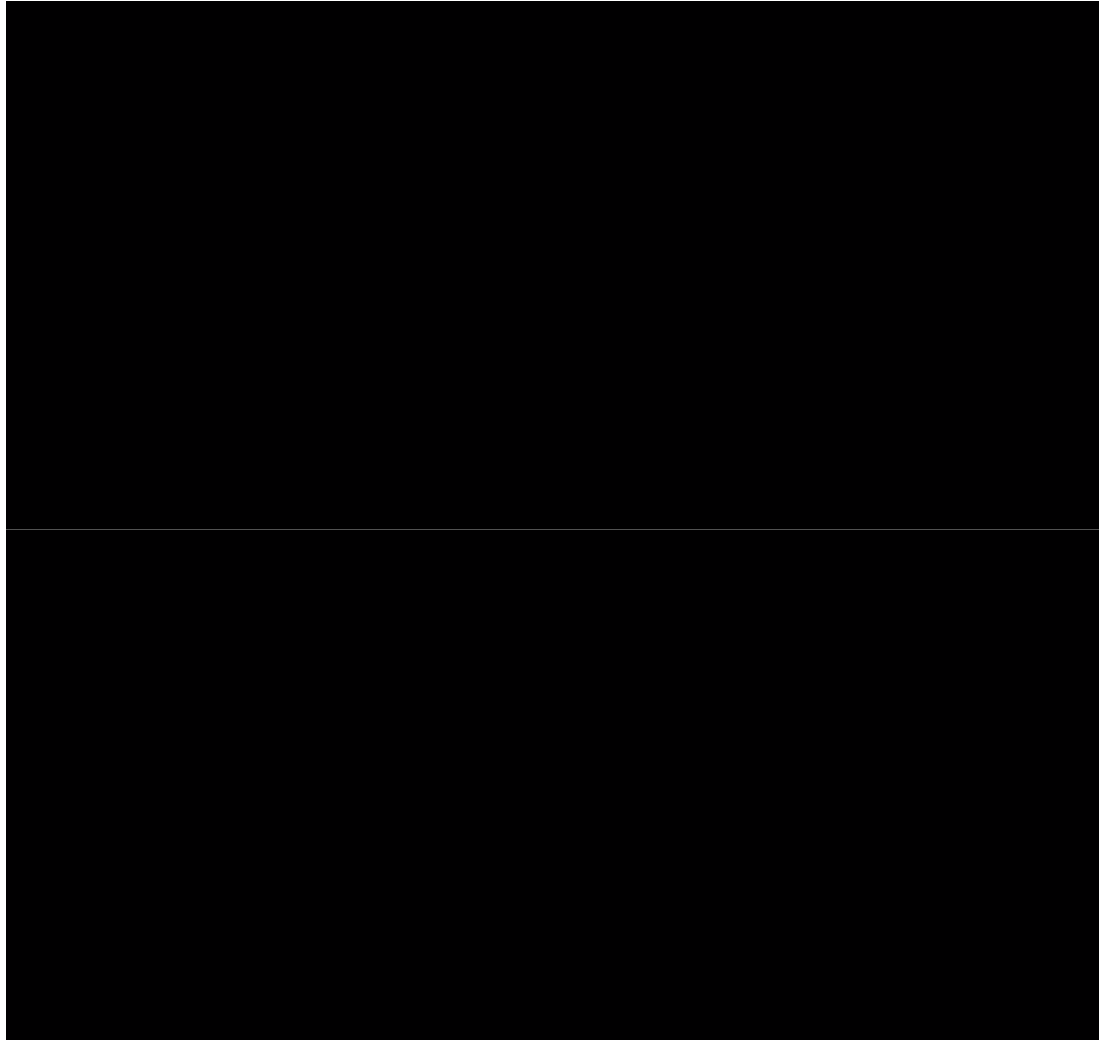

# Automation

## Areas of Possible Automation

- ✓ Mould Changing System
- ✓ Material Feeding System
- ✓ Product Removal & Transfer System
- ✓ **Information Management System**





# Automation

## Information Management System

➤ Product Data Analysis Software



PDA SOFTWARE INSTALLED



# Elements of Efficiency

- ✓ Factory & Shop Floor Layout
- ✓ Waste Elimination at Various Stages
- ✓ Automation for Consistency
- ✓ **Selection of Appropriate Process Technology**
- ✓ Selection of Appropriate Equipments

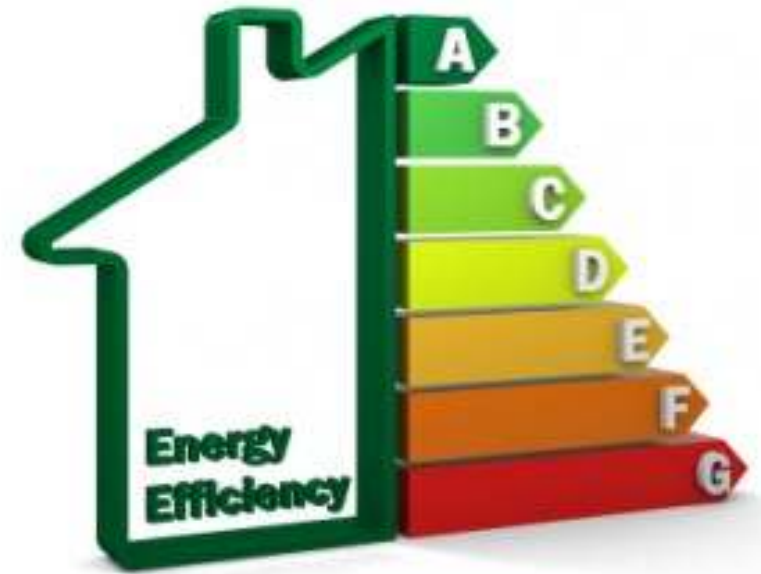

# Selection of Appropriate Processing Technology

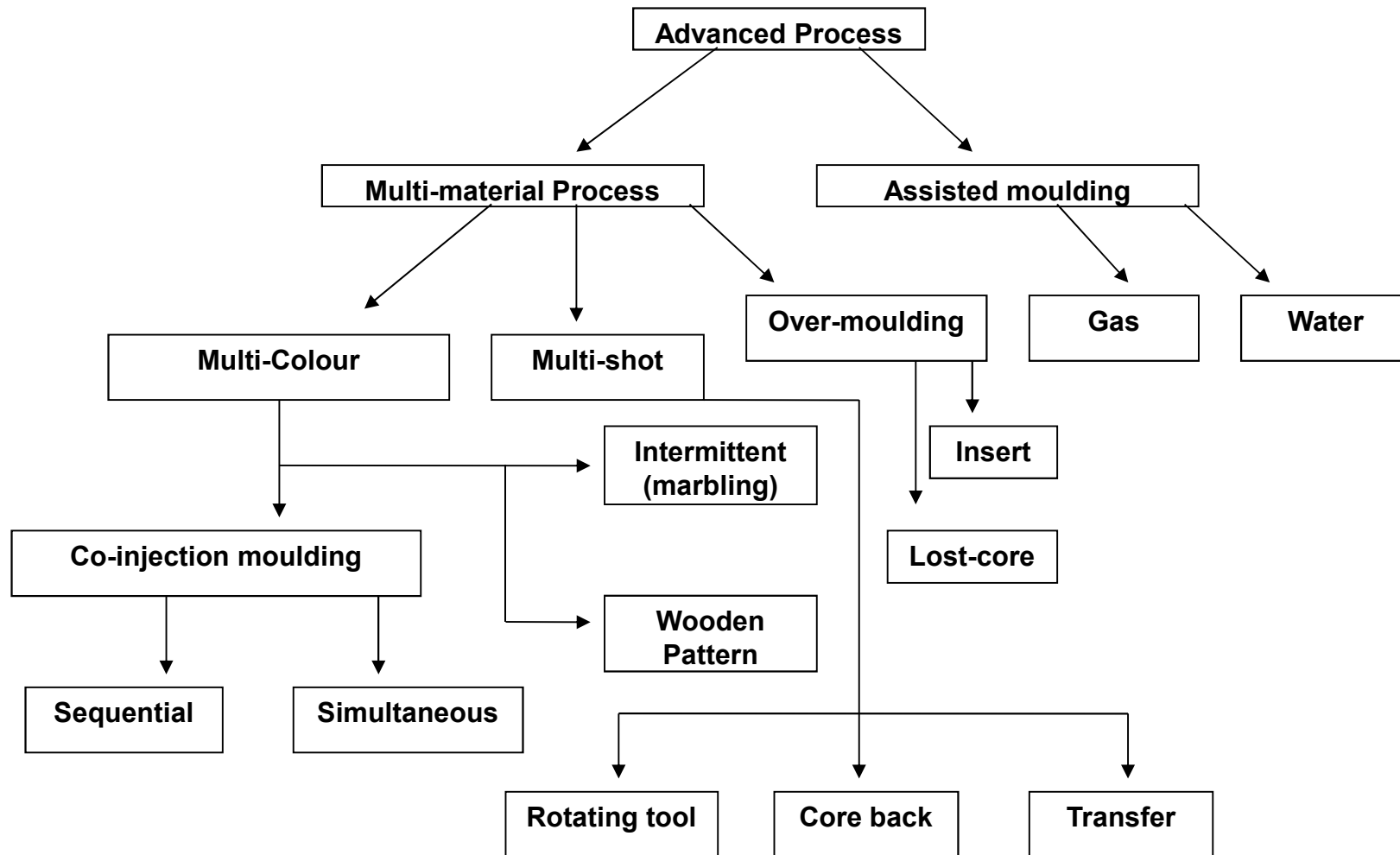

# Elements of Efficiency

- ✓ Factory & Shop Floor Layout
- ✓ Waste Elimination at Various Stages
- ✓ Automation for Consistency
- ✓ Selection of Appropriate Process Technology
- ✓ **Selection of Appropriate Equipments**

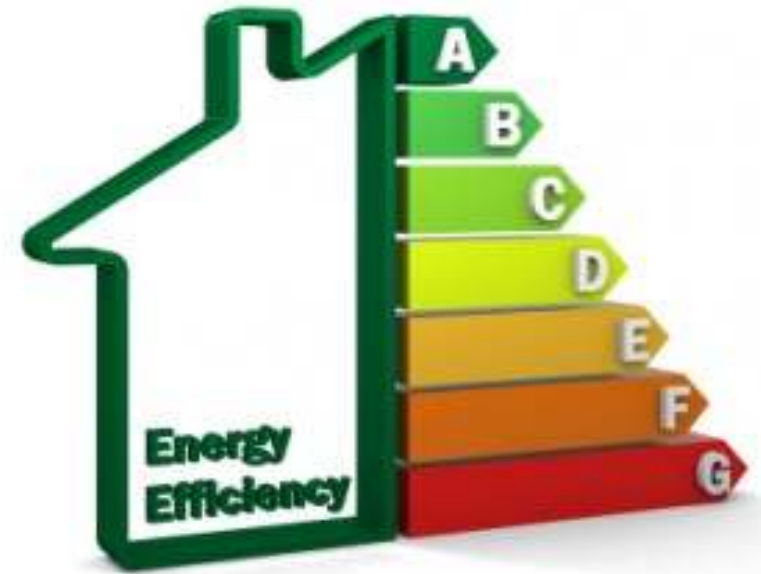

# Selection of Appropriate Equipments

- ✓ Injection Moulding Machine
  - Clamp unit
  - Injection Unit
  - Energy Platform
  
- ✓ Mould
  - Number of Cavities
  - Mould Material
  
- ✓ Peripheral Equipments / Auxiliaries
  - Chiller
  - Material Conveying System
  - Material Drying System
  - Scrap Grinder
  
- ✓ Utilities
  - Cooling Tower
  - Air Compressor



# Measurement Matrices

- ✓ Uptime %
- ✓ Rejection %
- ✓ Revenue Per Sq. Meter
- ✓ Profit Per Sq. Meter
- ✓ Revenue Per Person
- ✓ Profit Per Person

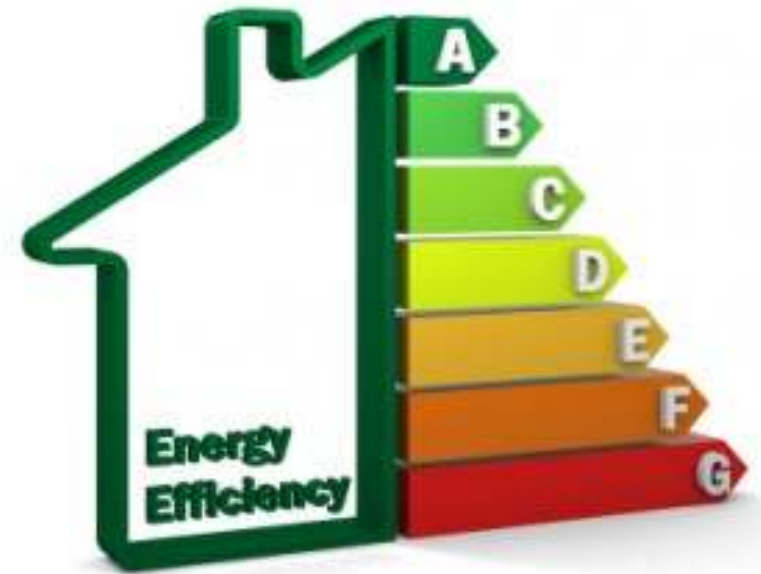

# Create an Efficient Moulding Shop



THANK YOU  
FOR YOUR  
TIME